

LOAD CHART & RIGGING PRACTICE

STIFF BOOM CRANE

National 890D - 23 Ton Crane



CraneSafe Certification

Document #:
Stiff Boom Crane Practice
LCR.SB40.NA890D.23.P1

22 December 2008

CraneSafe
CERTIFICATION

CraneSafe Certification + Fulford Harbour Group
Tel: 604.952.6033 | www.fulford.ca

Introduction

These 10 questions are for you to use to help get ready for the load chart and rigging part of the CraneSafe Certification assessment for Stiff Boom Crane.

The questions on your assessment will be different from these but will be presented in the same format as these questions.

Following the questions are load charts and jib rating charts. We have not included all of the charts for this crane - but everything you need to answer the questions is included in the load and jib charts you have here. You do not need the crane manual or full load chart package to answer the questions.

Following the load charts are rigging tables - use these to help answer the rigging questions included in the practice questions. These same rigging charts will be used in your assessment so it is a good idea to become familiar with them.

Attached to the back of this practice exercise is an answer sheet. The answer sheet explains how we arrived at the correct answer and you can use this to help work through any questions you may have gotten wrong.

The crane industry in BC has stated that operators must get a minimum of seven out of ten questions right on the load chart and rigging part of the assessment to be competent.

Operator Information *This section to be completed by Operator*

Operator Name: _____

Employer: _____

Make & Model of Crane _____

Signature: _____

Assessor Information *This section to be completed by Assessor*

Assessor Name: _____

Date of Assessment: Month _____ Day _____ Year _____

Place of Assessment: _____

Load Chart & Rigging Questions

1. What is the net capacity?

- Main boom length – 78 feet
- Radius – 35 feet
- 2 parts of line on the one sheave block
- Jib stowed
- Rigging – 75 pounds

Answer: _____ pounds

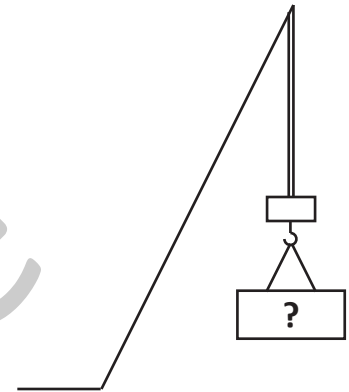

2. What is the maximum radius the load can be placed?

- Main boom length – 54 feet
- 2 parts of line on the one sheave block
- Jib stowed
- Rigging – 100 pounds
- Load weight – 13,500 pounds

Answer: _____ feet

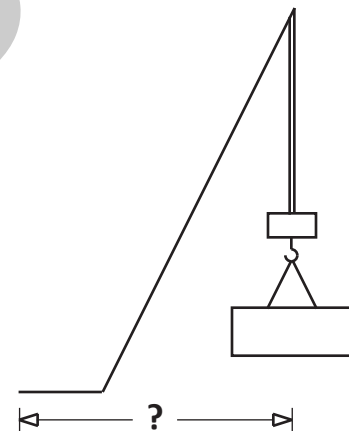

3. What is the net capacity?

- Main boom length – 90 feet
- Single part line on downhaul weight
- No jib stowed
- Radius – 45 feet
- Rigging – 50 pounds

Answer: _____ pounds

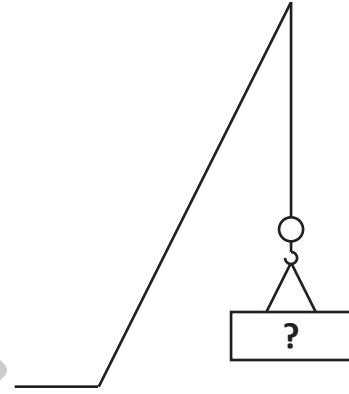

4. What is the maximum radius the load can be placed?

- Main boom length – 90 feet
- Erected jib length – 25 feet
- Single part line on downhaul weight
- Load weight – 3,500 pounds
- Rigging – 50 pounds

Answer: _____ feet

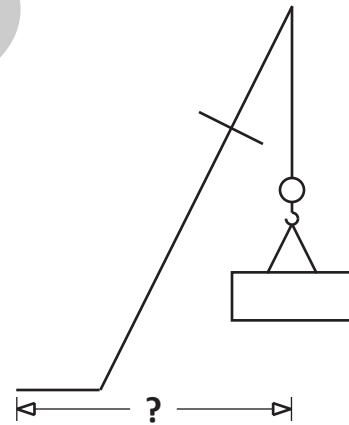

5. What is the lowest boom angle allowed when placing this load?

- Main boom length – 66 feet
- Erected jib length – 44 feet
- Single part line on downhaul weight
- Load weight – 2,350 pounds
- Rigging – 75 pounds

Answer: _____ degrees

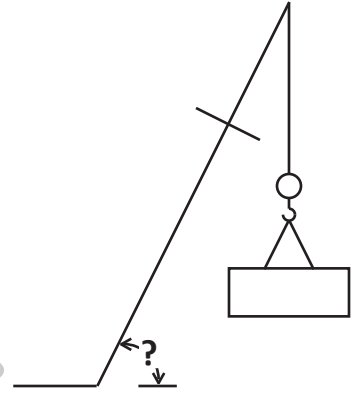

6. A 9,000 pound load is being lifted using chain slings in a basket hitch configuration. The basket hitches are at a 30 degree angle.

What is the minimum size required for the two basket hitches?

Answer: _____ inch

7. A 3,000 pound load of pipe is being lifted using nylon web slings. The two-leg bridle hitch is choked at a 45 degree angle.

What is the minimum size of slings required?

Answer: _____ inch

8. What is the minimum size of two-leg wire rope bridle required to lift a load of 15,000 pounds? The slings are at a 30 degree angle.

Answer: _____ inch

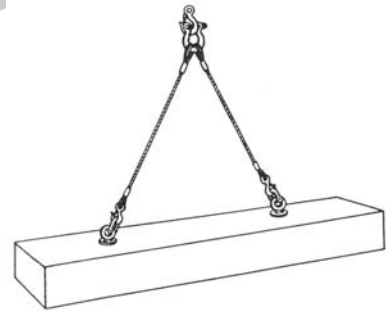

9. What is the minimum size of chain slings required to lift a load of 12,000 pounds?
The two-leg bridle is in a choker hitch configuration at a 45 degree angle.

Answer: _____ inch

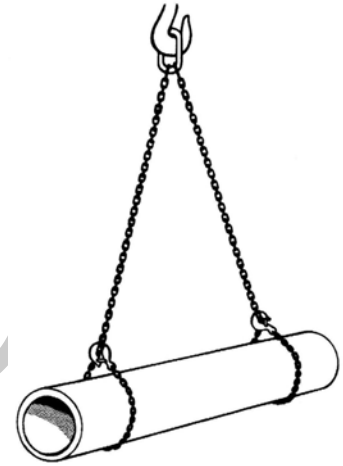

10. What is the minimum size of web slings required to lift a load of 8,000 pounds?
The two slings are in a basket hitch configuration at a 60 degree angle.

Answer: _____ inch

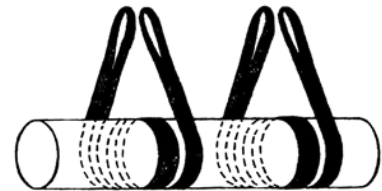

Load Charts

Load Rating Chart: Series 890D (27.43 m) Boom with 44 ft (13.41 m) Jib

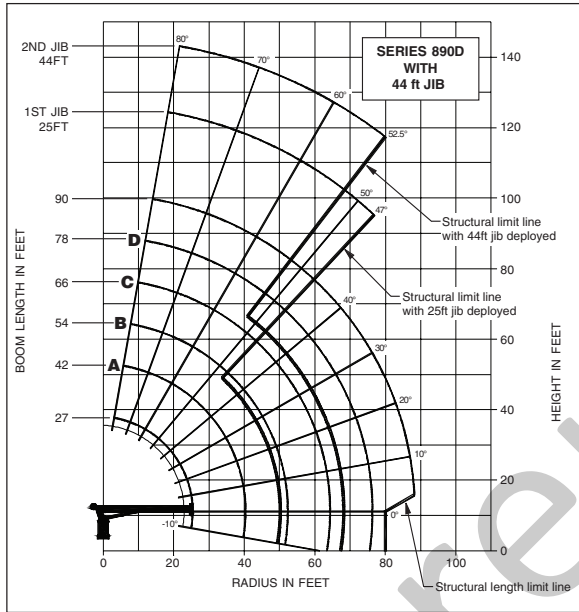

CAUTION:

- Do not operate crane booms, jib extensions, any accessories or loads within 10 ft (3m) of live power lines or other conductors of electricity.
- Jib and boom capacities shown are maximum for each section.
- Do not exceed capacities at reduced radii
- Load ratings shown on the load rating charts are maximum allowable loads with the outriggers properly extended on a firm, level surface and the crane leveled and mounted on a factory recommended truck.
- Always level the crane with the level indicator located on the crane.
- The operator must reduce load to allow for factors such as wind, ground conditions, operating speeds and their effects on freely suspended loads.
- Overloading this crane may cause structural collapse or instability.
- Weights on any accessories attached to the boom or loadline must be deducted from the load chart capacities.
- Do not exceed jib capabilities at any reduced boom lengths.
- Do not deadhead lineblock against boom tip when extending boom or winching up.
- Keep at least three wraps of loadline on drum at all times.
- Use only specified cable with this machine.

**SERIES 890D
BOOM WITH
44 ft (13.41 M) JIB**

NOTE:

- Operate with jib by radius when main boom is fully extended. If necessary increase boom angle to maintain loaded radius.
- Operate with jib by boom angle when main boom is not fully extended. Do not exceed rated jib capacities at any reduced boom lengths.

**LOADLINE EQUIPMENT
DEDUCT (lb)**

Downhaul weight	150 lb (68 kg)
One sheave block	305 lb (138 kg)
Two sheave block	355 lb (161 kg)
Three sheave block	575 lb (261 kg)

Load Rating Chart: Series 890D (27.43 m) Boom with 44 ft (13.41 m) Jib

LOAD RADIUS (FEET)	LOADED BOOM ANGLE	27 ft BOOM (lb)	LOADED BOOM ANGLE	A 42 ft BOOM (lb)	LOADED BOOM ANGLE	B 54 ft BOOM (lb)	LOADED BOOM ANGLE	C 66 ft BOOM (lb)	LOADED BOOM ANGLE	D 78 ft BOOM (lb)	LOADED BOOM ANGLE	90 ft BOOM (lb)	LOAD RADIUS (FEET)	LOADED BOOM ANGLE	25 ft JIB (lb)	LOADED BOOM ANGLE	44 ft JIB (lb)
5	77	46,000											30	76.5	4,800	79	3,100
8	70	32,300											35	74	4,300	77	2,900
10	65	26,700	75.5	23,400	79	21,900							40	71.5	3,650	75	2,700
12	60	22,800	72.5	20,400	77	18,700							45	68.5	3,000	73	2,500
14	54.5	19,900	69.5	17,800	75	16,400	78	15,050					50	66	2,450	71	2,300
16	49	17,500	66.5	15,800	72.5	14,400	76	13,250	79	12,300			55	63	2,000	69	2,100
20	35	13,700	60	12,700	68	11,800	72.5	10,900	76	10,000	78	9,750	60	60	1,600	66	1,800
25			51.5	10,200	62	9,500	68	8,800	72	8,150	74.5	7,850	65	57	1,300	63.5	1,500
30			42	8,300	55.5	7,950	63.5	7,100	68	6,500	71.5	6,250	70	54	1,000	61	1,250
35			31	6,550	49	6,500	58	6,050	64	5,550	68	5,300	75	50.5	750	58.5	1,050
40					41	5,450	53	5,150	60	4,950	64.5	4,500	80	47	500	55.5	850
45					32	4,500	47	4,400	55	4,100	61	3,900	85			52.5	650
50							18.5	3,300	40.5	3,700	50.5	3,550					
55									32.5	3,000	45.5	3,000					
60									22.5	2,350	39.5	2,600					
65											33	2,150					
70											25	1,650					
75											12	850					
80																	
85																	
	0	6,600	0	3,000	0	1,600	0	600									
	ADD TO CAPACITIES WHEN NO JIB STOWED (lb)	800		500		400		350		300		250					

Shaded areas are structurally limited capacities.

These charts are for assessment purposes only and should not be used to operate a crane.

The individual crane's load chart, operating instructions and other instructional plates must be read and understood prior to operating the crane.

Boom and Jib Combinations Data

Available in five basic models.

Model 851D – Equipped with a 21 ft. to 51 ft. (6.4-15.5 m) three-section boom. Maximum tip height is 62 ft. (18.9 m).



Model 860D – Equipped with a 24 ft. to 60 ft. (7.31-18.28 m) three-section boom. Maximum tip height is 71 ft. (21.64 m).



Model 880D – Equipped with a 24 ft. 6 in. to 80 ft. (7.46-24.38 m) four-section boom. This model can be equipped with a 22-39 ft. (6.70-11.88 m) two-section jib. Maximum tip height w/39 ft. (11.88 m) jib is 128 ft. (39.01 m).

24'6"-80' (7.46-24.38 m) four-section boom.



24'6"-80' (7.46-24.38 m) four-section boom. **8FJ39M** 22-39 ft. (6.70-11.88 m) two-section jib



Model 890D – Equipped with a 27 ft. to 90 ft. (8.23-27.43 m) four-section boom. This model can be equipped with a 25-44 ft. (7.62-13.41 m) two-section jib. Maximum tip height w/44 ft. (13.41 m) jib is 143 ft. (43.58 m).

27'-90' (8.23-27.43 m) four-section boom.



27'-90' (8.23-27.43 m) four-section boom. **8FJ44M** 25-44 ft. (7.62-13.41 m) two-section jib



Model 8100D – Equipped with a 29 ft. 6 in. to 100 ft. (8.99-30.48 m) four-section boom. This model can be equipped with a 25-44 ft. (7.62-13.41 m) two-section jib. Maximum tip height w/44 ft. (13.41 m) jib is 152 ft. (46.32 m).

29'6" - 100' (8.99-30.48 m) four-section boom.



29'6" - 100' (8.99-30.48 m) four-section boom. **8FJ44M** 25-44 ft. (7.62-13.41 m) two-section jib



Note: Maximum tip is measured with outriggers/stabilizers fully extended.

800D Winch Data

800D Winch Data

- All winch pulls and speeds in this chart are shown on the **fourth** layer
- Winch line pulls would increase on the first, second and third layers
- Winch line speed would decrease on the first, second and third layers
- Winch line pulls may be limited by the winch capacity or the ANSI 5 to 1 cable safety factor
- Hook blocks are rated at maximum capacity for the block. **Do not exceed rated cable pull with any block.**

Winch	Cable Supplied	Average Breaking Strength	1 Part Line	2 Part Line	3 Part Line	4 Part Line	5 Part Line	6 Part Line
			Lift and Speed	Lift and Speed	Lift and Speed	Lift and Speed	Lift and Speed	Lift and Speed
Standard Planetary Winch	9/16" Diameter Rotation Resistant	38,600 lb (17 463 kg)	7,700 lb (3492 kg) 147 fpm (45 m/min)	15,400 lb (6 985 kg) 73 fpm (22 m/m)	23,100 lb (10 477 kg) 49 fpm (15 m/m)	30,800 lb (13 970 kg) 38 fpm (11 m/m)	38,500 lb (17 163 kg) 29 fpm (9 m/m)	46,000 lb (20 865 kg) 25 fpm (8 m/m)



Winch	Bare Drum Pull	Allowable Cable Pull
With standard rotation resistant rope	10,200 lb (4627 kg)	7,700 lb (3493 kg)

Block Type	Rating	Weight
Downhaul Weight	3.85 USt (3.49 t)	150 lb (68 kg)
1 Sheave Block	11.55 USt (10.48 t)	305 lb (138 kg)
2 Sheave Block	19.25 USt (17.46 t)	355 lb (161 kg)
3 Sheave Block	30.00 USt (27.21 t)	575 lb (261 kg)



These charts are for assessment purposes only and should not be used to operate a crane.

The individual crane's load chart, operating instructions and other instructional plates must be read and understood prior to operating the crane.

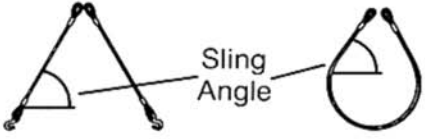
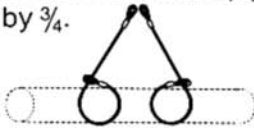
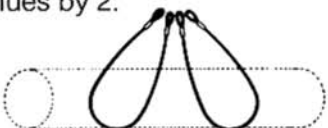
Wire Rope Slings

6 x 19 Classification Group, Improved Plow Steel, IWRC						
Rope Diameter (Inches)	MAXIMUM SAFE WORKING LOADS — POUNDS Safety Factor = 5 per OH&S Regulations					
	Single Vertical Hitch	Single Choker Hitch	Single Basket Hitch (Vertical Legs)	2-Leg Bridle Hitch & Single Basket Hitch With Legs Inclined		
					60°	45°
3/16	650	480	1,300	1,100	900	650
1/4	1,150	860	2,300	2,000	1,600	1,150
5/16	1,750	1,300	3,500	3,000	2,500	1,750
3/8	2,550	1,900	5,100	4,400	3,600	2,550
7/16	3,450	2,600	6,900	6,000	4,900	3,450
1/2	4,700	3,500	9,400	8,150	6,650	4,700
9/16	5,700	4,200	11,400	9,900	8,050	5,700
5/8	7,100	5,300	14,200	12,300	10,000	7,100
3/4	10,200	7,650	20,400	17,700	14,400	10,200
7/8	13,750	10,300	27,500	23,800	19,400	13,750
1	17,950	13,450	35,900	31,100	25,400	17,950
1 1/8	22,750	17,000	45,500	39,400	32,200	22,750
1 1/4	28,200	21,200	56,400	48,800	39,900	28,200
1 3/8	34,800	26,100	69,600	60,300	49,200	34,800
1 1/2	41,300	31,000	82,600	71,500	58,400	41,300
				If used with Choker Hitch multiply above values by 3/4. 		
				For Double Basket Hitch multiply above values by 2. 		
Note: Table values are for slings with eyes and thimbles in both ends, Flemish Spliced Eyes and mechanical sleeves.						

Chain Slings

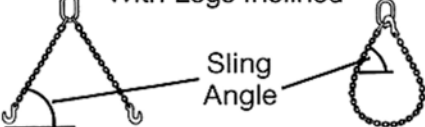
GRADE T (8) ALLOY STEEL						
Chain Size (Inches)	MAXIMUM SAFE WORKING LOADS — POUNDS Safety Factor = 5 per OH&S Regulations					
	Single Vertical Hitch	Single Choker Hitch	Single Basket Hitch (Vertical Legs)	2-Leg Bridle Hitch & Single Basket Hitch With Legs Inclined		
					60°	45°
1/4	2,800	2,100	5,600	4,850	3,959	2,800
3/8	5,680	4,260	11,360	9,838	8,032	5,680
1/2	9,600	7,200	19,200	16,627	13,574	9,600
5/8	14,480	10,860	28,960	25,079	20,475	14,480
3/4	22,640	16,980	45,280	39,212	32,013	22,640
7/8	27,360	20,520	54,720	47,388	38,687	27,360
1	38,160	28,620	76,320	66,093	53,958	38,160
1 1/4	57,840	43,380	115,680	100,179	81,786	57,840

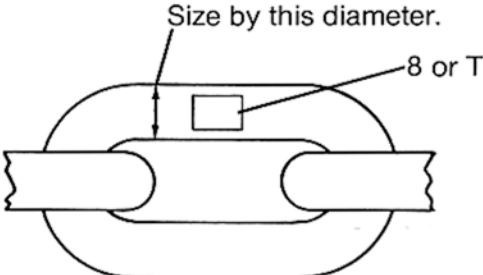

Size by this diameter.

8 or T

Use only alloy steel chain. Links will be stamped with 8 or T.

If used with Choker Hitch multiply above values by 3/4.

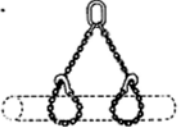

For Double Basket Hitch multiply above values by 2.

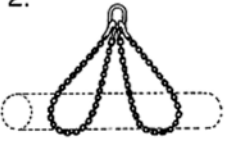

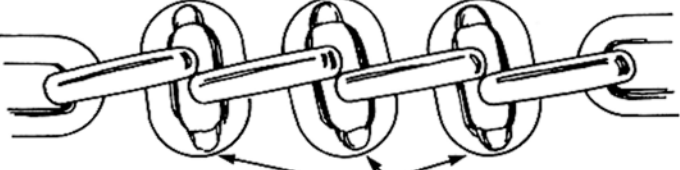

Strength based on ISO Standards and adjusted to reflect a safety factor of 5.



Discard if more than 10% wear at bearing surfaces.

Nylon Web Slings

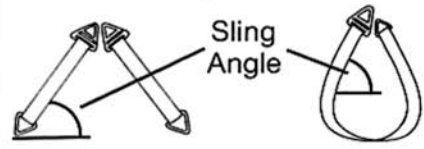
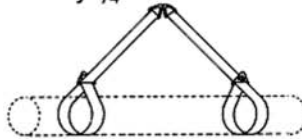
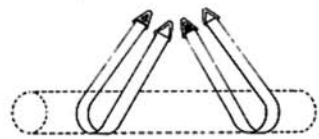
6800 lb/in Material						
MAXIMUM SAFE WORKING LOADS — POUNDS (SAFETY FACTOR =5) (Eye & Eye, Twisted Eye, Triangle Fittings, Choker Fittings)						
Web Width (Inches)	Single Vertical Hitch	Single Choker Hitch	Single Basket Hitch (Vertical Legs)	2-Leg Bridle Hitch & Single Basket Hitch With Legs Inclined		
						
				60°	45°	30°
1	1,100	825	2,200	1,905	1,555	1,100
2	2,200	1,650	4,400	3,810	3,110	2,200
3	3,300	2,475	6,600	5,715	4,665	3,300
4	4,400	3,300	8,800	7,620	6,220	4,400
5	5,500	4,125	11,000	9,525	7,775	5,500
6	6,600	4,950	13,200	11,430	9,330	6,600
				If used with Choker Hitch multiply above values by $\frac{3}{4}$. 		
				For Double Basket Hitch multiply above values by 2. 		
<ol style="list-style-type: none"> For safe working loads of endless or grommet slings, multiply above values by 2. Values have been adjusted to reflect fabrication efficiency (FE) using formulas and tables developed by the Web Sling Association. This accounts for strength loss due to stitching and manufacture. All web slings must carry a load rating tag as specified in OH&S Regulations. 						

Eye Bolts

Stock Diameter (Inches)	SAFE WORKING LOADS (LBS) CORRESPONDING TO ANGLE OF PULL			
	Vertical	60°	45°	Less than 45°
1/4	500	175	125	NOT RECOMMENDED
5/16	800	280	200	
3/8	1,200	420	300	
1/2	2,200	770	550	
5/8	3,500	1,225	875	
3/4	5,200	1,820	1,300	
7/8	7,200	2,520	1,800	
1	10,000	3,500	2,500	
1 1/4	15,200	5,320	3,800	
1 1/2	21,400	7,490	5,350	

1. SWL for plain (shoulderless) eye bolts are same as for shoulder bolts under vertical load. Angular loading is not recommended.
 2. Use only forged steel eye bolts.

SHOULDER BOLTS

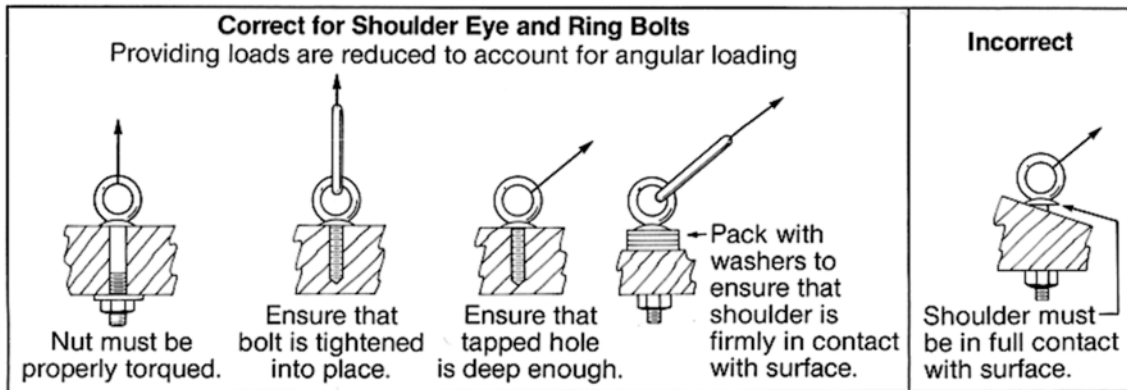

SHOULDERLESS BOLTS

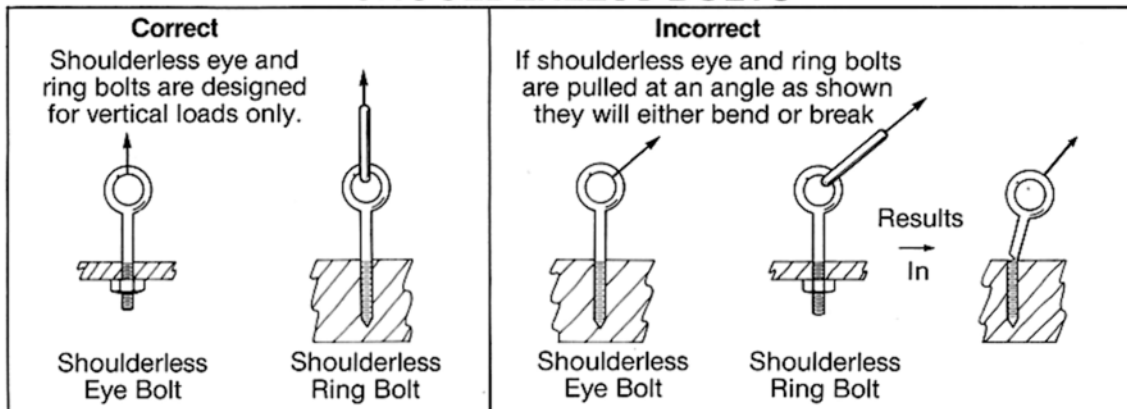

Answer Key

1. Answer: **5,170 pounds**

Deductions from Gross Capacity

Block	305 pounds
Rigging	75 pounds
	380 pounds

Gross capacity is 5,550 pounds with 78 feet of boom at a 35 foot radius.

5,550 pounds minus deductions of 380 pounds gives a Net Capacity of 5170 pounds.

2. Answer: **16 feet**

Gross Load on the crane

Block	305 pounds
Rigging	100 pounds
Load	13,500 pounds
	13,905 pounds

Gross Capacity at a 16 foot radius is 14,400 pounds which is greater than the Gross Load of 13,905 pounds.

3. Answer: **3,950 pounds**

Deductions from the Gross Capacity

Downhaul weight	150 pounds
Rigging	50 pounds
	200 pounds

Gross capacity is 3,900 pounds plus 250 pounds for *no jib stowed* which equals a new Gross Capacity of 4,150 pounds. 4150 pounds minus deductions of 200 pounds gives a Net Capacity of 3,950 pounds.

4. Answer: **35 feet**

Gross Load on the crane

Downhaul weight 150 pounds

Load 3,500 pounds

Rigging 50 pounds

3,700 pounds

Gross Capacity at a 35 foot radius is 4,300 pounds which is greater than the Gross Load of 3,700 pounds.

5. Answer: **75 degrees**

Gross Load on the crane is:

Downhaul weight 150 pounds

Load 2,350 pounds

Rigging 75 pounds

2,575 pounds

Gross Capacity at a 75 degree boom angle is 2,700 pounds which is greater than the Gross Load of 2,575 pounds.

6. Answer: **3/8 inch**

Capacity of **one** 3/8 inch chain in a basket hitch at a 30 degree angle is 5,680 pounds.

Capacity of **two** basket hitches is (2 x 5680) 11,360 pounds which is greater than the load of 9,000 pounds.

7. Answer: **3 inch**

Capacity of a 3 inch web sling bridle at a 45 degree angle is 4,665 pounds.

The two-leg bridle is choked so the capacity of 4,665 pounds **must be multiplied by .75**:

$4,665 \times .75 = 3498$ pounds which is greater than the load of 3,000 pounds.

8. Answer: **1 inch**

The capacity of a 1 inch two – leg bridle is 17,950 pounds.

9. Answer: **5/8 inch**

5/8": 20,475 pounds $\times .75 = 15,356$ pounds

1/2": 13,574 pounds $\times .75 = 10,180$ pounds (too small)

10. Answer: **3 inch**

The capacity of one 3 inch belt is 5,715 pounds.

$5,715 \text{ pounds} \times 2 = 11,430$ pounds